

SECTION J, INDOOR CABINETS AND ACCESSORIES, 6000 SERIES

FIGURE NUMBER	DESCRIPTION	PAGES
	GENERAL INFORMATION.....	J-iii
 UNIVERSAL CARD/STORAGE CABINET AND ACCESSORIES		
FIG. 006002	UNIVERSAL CARD/STORAGE CABINET, 72" HEIGHT.....	J-1
FIG. 006003	UNIVERSAL CARD/STORAGE CABINET, 42" HEIGHT.....	J-2
FIG. 006004	UNIVERSAL CARD/STORAGE CABINET, 23" RACK MOUNTING, 36" HEIGHT.....	J-3
	ACCESSORIES LIST.....	J-4
FIG. 006000	GENERAL INFORMATION - ADJUSTING UNIVERSAL SHELF.....	J-5
FIG. 006005	ADJUSTABLE SHELF.....	J-6
FIG. 006006	FLAT SURFACE SHELF.....	J-6
FIG. 006007	MAGNETIC TAPE REEL STORAGE SHELF.....	J-7
FIG. 006008	ESD WORK SURFACE KIT.....	J-7
FIG. 006009	CARD RETAINER.....	J-8
FIG. 006010	DRAWER ASSEMBLY.....	J-8
FIG. 006011	DOCUMENT POCKET.....	J-9
FIG. 006012	FLOOR ANCHOR KIT.....	J-9
FIG. 006013	WALL MOUNTING KIT FOR RACK MOUNTED CABINET.....	J-10
FIG. 006014	STABILIZING BRACKET FOR 36" OR 72" HEIGHT CABINET.....	J-11
FIG. 006015	FLOOR INSULATION KIT.....	J-11
FIG. 006018	STABILIZING BRACKET INSULATION KIT FOR HALF AND FULL HEIGHT CABINET.....	J-12

SECTION J, INDOOR CABINETS AND ACCESSORIES, 6000 SERIES

FIGURE NUMBER	DESCRIPTION	PAGES
	INDOOR CABINETS AND ACCESSORIES	
FIG. 215011	DESK-TOP CABINET, 24”H X 24”W X 24”D	J-13
FIG. 215039	CABINET, 26” H X 28” W X 15” D.....	J-14
FIG. 211855	SHELF, VENTED, 4-POINT MOUNTING.....	J-15

INDOOR CABINETS

GENERAL INFORMATION

THE INDOOR CABINETS INCLUDED ARE REPRESENTATIVE OF THE MANY VERSIONS AVAILABLE FROM NEWTON.

FOR ADDITIONAL INFORMATION, PLEASE COMMUNICATE WITH YOUR NEWTON CUSTOMER SERVICE REPRESENTATIVE.

PHONE: (919) 575-6426

FAX: (919) 575-4708

OR VISIT OUR WEB SITE: www.newtoninst.com

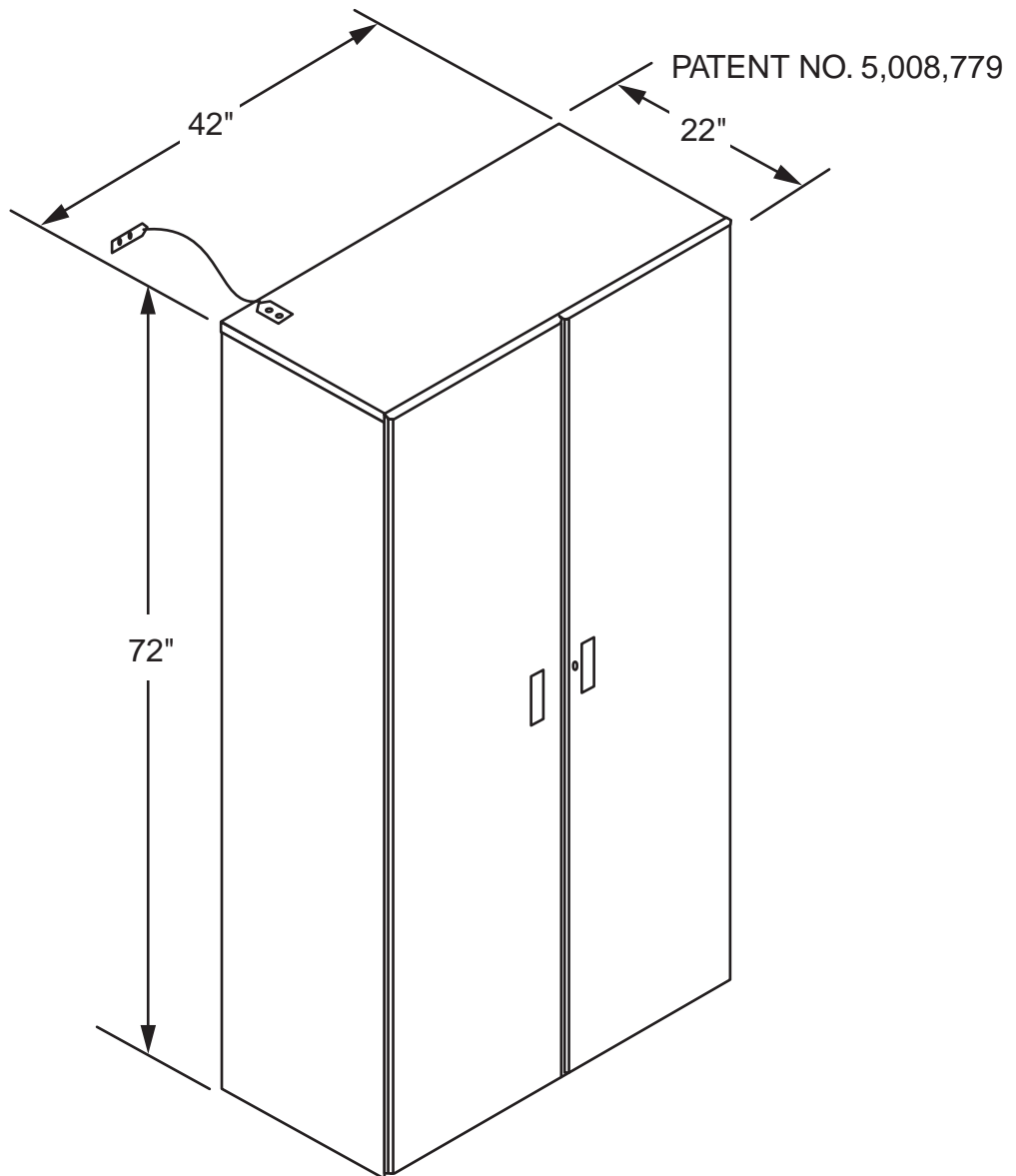

NOTES:

1. XX= FINISH CODE; STANDARD FINISH, XX=73 (BEIGE). OTHER COLORS AVAILABLE UPON REQUEST.
2. CABINET INCLUDES 8 ADJUSTABLE SHELVES (FIG. 006005) AND TWO FIXED SHELVES, CREATING EIGHT STORAGE SPACES (REFER TO FIG. 006000).
3. REFER TO ACCESSORIES FOR ADDITIONAL SHELVES.
4. CABINET INCLUDES DOOR LOCK.
5. CABINET IS EQUIPPED WITH LEVELERS ON ALL FOUR CORNERS.
6. FLOOR ANCHORED (FOR HARDWARE, REFER TO ACCESSORIES).
7. EACH CARD SHELF HAS 27 SLOTS SPACED ON 5/8" CENTERS AND ACCEPTS CARDS UP TO 20" DEEP.
8. CARD GUIDES CONTAIN ELECTROSTATIC DISSIPATIVE PROPERTIES.

ORDERING NUMBER: 00600200XX

UNIVERSAL/CARD STORAGE CABINET, 72" HEIGHT

FIG. 006002

PATENT NO. 5,008,779

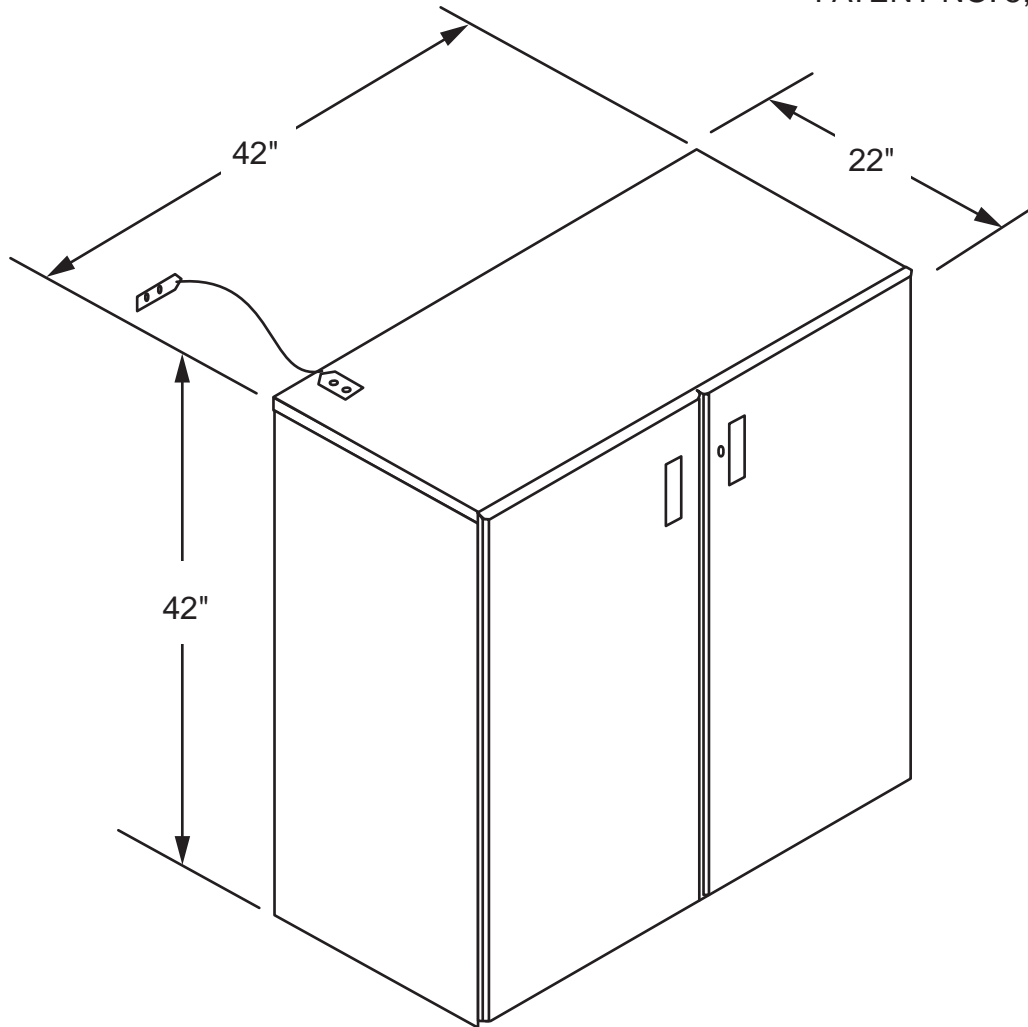

NOTES:

1. XX= FINISH CODE; STANDARD FINISH, XX=73 (BEIGE). OTHER COLORS AVAILABLE UPON REQUEST.
2. CABINET INCLUDES SIX ADJUSTABLE SHELVES (FIG. 006005) AND TWO FIXED SHELVES, CREATING 6 ADJUSTABLE STORAGE SPACES. (REFER TO FIG. 006000).
3. REFER TO ACCESSORIES FOR ADDITIONAL SHELVES.
4. CABINET INCLUDES DOOR LOCK.
5. CABINET IS EQUIPPED WITH LEVELERS ON ALL FOUR CORNERS.
6. FLOOR ANCHORED (FOR HARDWARE, REFER TO ACCESSORIES).
7. EACH CARD SHELF HAS 27 SLOTS SPACED ON 5/8" CENTERS AND ACCEPTS CARDS UP TO 20" DEEP.
8. CARD GUIDES CONTAIN ELECTROSTATIC DISSIPATIVE PROPERTIES.

ORDERING NUMBER: 00600300XX

UNIVERSAL CARD/STORAGE CABINET, 42" HEIGHT

FIG. 006003

PATENT NO. 5,008,779

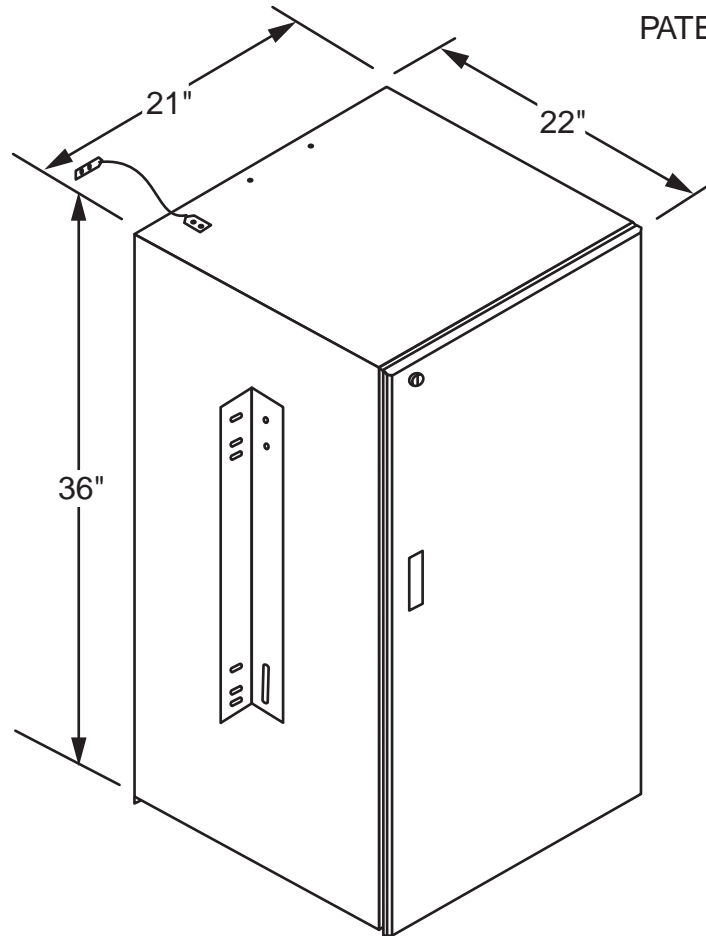

NOTES:

1. XX= FINISH CODE; STANDARD FINISH, XX= 73 (BEIGE). OTHER COLORS AVAILABLE UPON REQUEST.
2. CABINET INCLUDES THREE ADJUSTABLE SHELVES (FIG. 006005) AND TWO PLAIN SHELVES, CREATING THREE ADJUSTABLE STORAGE SPACES (REFER TO FIG. 006000).
3. REFER TO ACCESSORIES FOR ADDITIONAL SHELVES.
4. CABINET INCLUDES DOOR LOCK.
5. 23" RACK MOUNTING OR WALL MOUNTING (FOR HARDWARE, REFER TO ACCESSORIES).
6. MOUNTING BRACKETS ADAPT TO EQUIPMENT RACKS WITH 1" OR 1-3/4" MOUNTING SPACES.
7. EACH CARD SHELF HAS 27 SLOTS SPACED ON 5/8" CENTERS AND ACCEPTS CARDS UP TO 20" DEEP.
8. CARD GUIDES CONTAIN ELECTROSTATIC DISSIPATIVE PROPERTIES.
9. ASSEMBLY INSTRUCTIONS SHIPPED WITH EACH CABINET.

UNIVERSAL CARD/STORAGE CABINET,
23" RACK MOUNTING, 36" HEIGHT

ORDERING NUMBER: 00600400XX

FIG. 006004

ACCESSORIES

THE FOLLOWING ACCESSORIES ARE FOR USE WITH THE FIG. 006002, 006003 OR 006004 UNIVERSAL CARD/STORAGE CABINETS AS NOTED.

FIG. NO.	DESCRIPTION	USE WITH FIG. NO.
006005	ADJUSTABLE SHELF	006002, 006003, 006004
006006	FLAT SURFACE SHELF	006002, 006003, 006004
006007	MAGNETIC TAPE REEL STORAGE SHELF	006002, 006003, 006004
006008	ESD WORK SURFACE KIT	006003
006009	CARD RETAINER	006002, 006003, 006004
006010	DRAWER ASSEMBLY	006002, 006003, 006004
006011	DOCUMENT POCKET	006002, 006003, 006004
006012	FLOOR ANCHOR KIT	006002, 006003
006013	WALL MOUNTING KIT	006004
006014	STABILIZING BRACKET KIT	006002, 006003
006015	FLOOR INSULATION KIT	006002, 006003

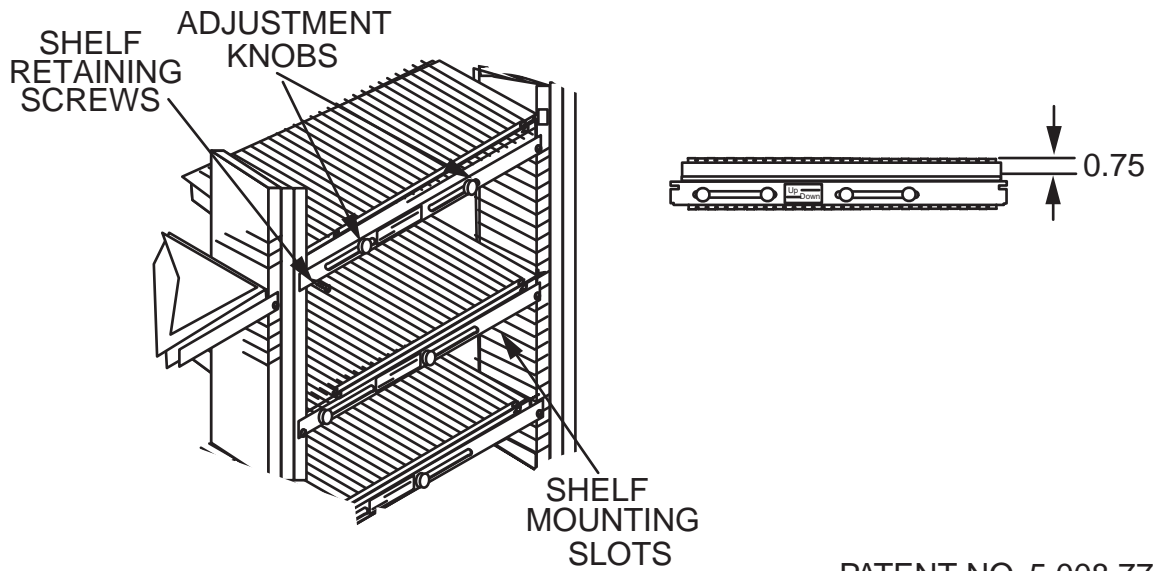

PATENT NO. 5,008,779

NOTES:

1. UNIVERSAL SHELF FITS ALL NEWTON UNIVERSAL CARD/STORAGE CABINETS.
2. SHELF MOUNTING SLOTS ARE 3/4" APART. SHELF SLIDES INTO SLOT AND IS HELD IN PLACE WITH TWO 8-32 SELF-TAPPING SCREWS. FROM THIS FIXED POSITION, TOP OF SHELF WITH CARD GUIDES WILL MOVE 3/4" UPWARD BY SLIDING KNOBS TO THE RIGHT. WITH SLOTS 3/4" APART AND 3/4" FINE ADJUSTMENT, THIS CABINET WILL ACCEPT CARDS OF ALL HEIGHTS.
3. EACH CARD SHELF HAS 27 SLOTS SPACED ON 5/8" CENTERS AND ACCEPTS CARDS UP TO 20" DEEP.

GENERAL INFORMATION;
ADJUSTING UNIVERSAL SHELF

FIG. 006000

NOTES:

1. STANDARD FINISH IS ZINC PLATED AND GOLD CHROMATE.
2. ADJUSTABLE SHELF FITS ALL NEWTON UNIVERSAL CARD/STORAGE CABINETS.
3. TO MOUNT IN CABINET, SLIDE INTO SLOTS ALONG SIDES OF CABINET. SELF-TAPPING SCREWS HOLD SHELF IN PLACE. (REFER TO FIG. 006000).
4. SHELF WILL ADJUST UP TO 3/4" BY MOVING KNOBS IN SLOTS (TO THE RIGHT - UP, TO THE LEFT - DOWN); REFER TO FIG 006000.

STOCK LIST

ITEM	QTY.	DESCRIPTION
1	1	SHELF ASSEMBLY
2	2	8-32 X 1/2 SELF-TAPPING SCREW

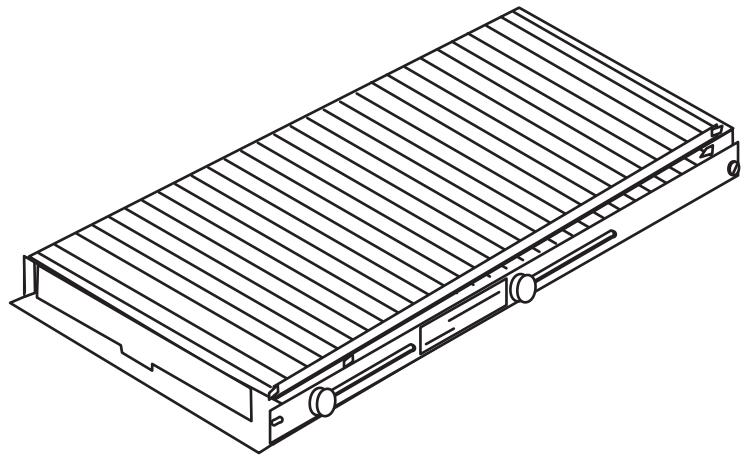

PATENT NO. 5,008,779

ORDERING NUMBER: 0060050010

ADJUSTABLE SHELF

FIG. 006005

NOTES:

1. STANDARD FINISH IS ZINC PLATED AND GOLD CHROMATE.
2. WHEN FLAT STORAGE IS NEEDED, ORDER THIS SHELF. SHELF FITS ALL NEWTON UNIVERSAL CARD/STORAGE CABINETS.
3. CARD GUIDE SLOTS ARE MOUNTED ON BOTTOM OF SHELF ONLY.
4. TO MOUNT IN CABINET, SLIDE INTO SLOTS ALONG SIDES OF CABINET. SELF-TAPPING SCREWS HOLD SHELF IN PLACE.

STOCK LIST

ITEM	QTY.	DESCRIPTION
1	1	SHELF ASSEMBLY
2	2	8-32 X 1/2 SELF-TAPPING SCREW

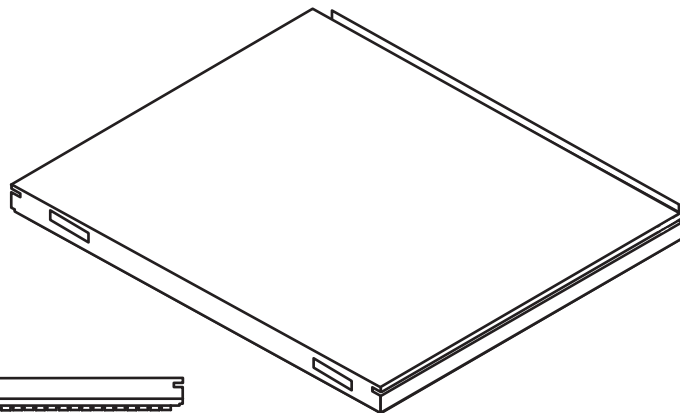

ORDERING NUMBER: 0060060010

FLAT SURFACE SHELF

FIG. 006006

NOTES:

1. STANDARD FINISH IS ZINC PLATED AND GOLD CHROMATE.
2. HOLDS UP TO 14 10-1/2" TAPE REELS OF ALL CARTRIDGE TYPES. SHELF FITS ALL NEWTON UNIVERSAL CARD/STORAGE CABINETS.
3. TO MOUNT IN CABINET, SLIDE INTO SLOTS ALONG SIDES OF CABINET. SELF-TAPPING SCREWS HOLD SHELF IN PLACE.
4. TAPE REELS NOT INCLUDED.

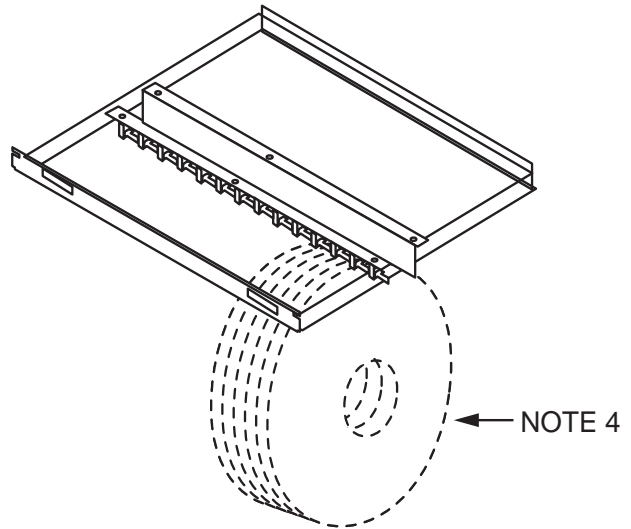

STOCK LIST

ITEM	QTY.	DESCRIPTION
1	1	SHELF ASSEMBLY
2	2	8-32 X 1/2 SELF-TAPPING SCREW

ORDERING NUMBER: 0060070010

MAGNETIC TAPE REEL STORAGE SHELF

FIG. 006007

NOTES:

1. ESD WORK SURFACE IS STATIC DISSIPATIVE PER EOS/ESD S-4.
2. FOR USE ON TOP SURFACE OF FIG. 006003 (OR EQUIVALENT).

STOCK LIST

ITEM	QTY.	DESCRIPTION
1	1	PAD
2	1	WRIST STRAP
3	1	GROUND STRAP
4	1	STACKING SNAP

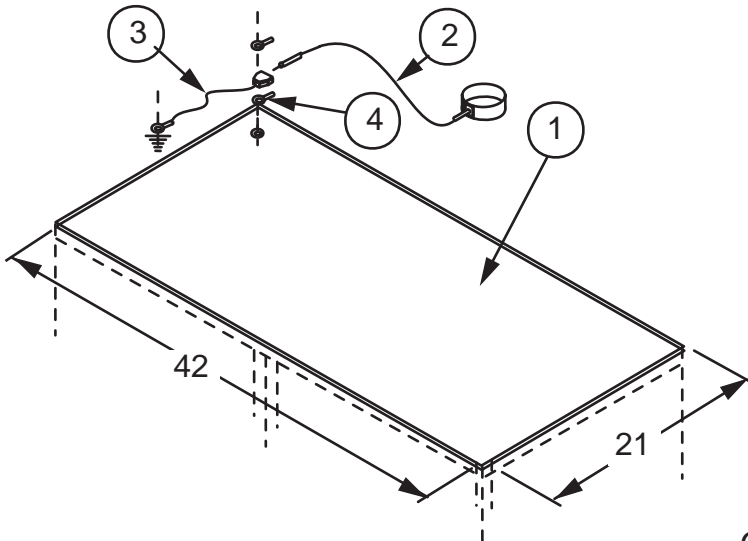

ORDERING NUMBER: 0060080000

ESD WORK SURFACE KIT

FIG. 006008

STOCK LIST

ITEM	QTY.	DESCRIPTION
1	2	WIRE CLIP
2	2	8-32 X 1/2 SELF-TAPPING SCREW
3	1	WIRE CARD RETAINER

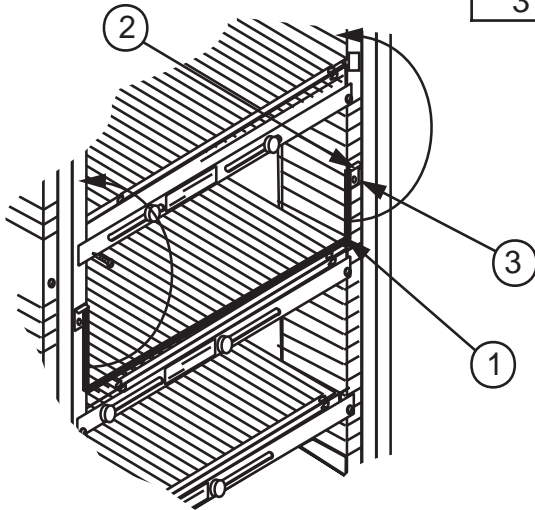

ORDERING NUMBER: 0060090011

CARD RETAINER

FIG. 006009

NOTES:

1. XX= FINISH CODE; STANDARD FINISH, XX= 73 (BEIGE). OTHER COLORS AVAILABLE UPON REQUEST.
2. TO MOUNT IN CABINET, SLIDE INTO SLOTS ALONG SIDES OF CABINET. DRAWER FITS ALL NEWTON UNIVERSAL CARD/STORAGE CABINETS.
3. CARD GUIDE SLOTS ARE MOUNTED ON BOTTOM OF FIXED DRAWER HOUSING.
4. DRAWER SLIDES HAVE STOPS LOCATED AT FULL OPEN POSITION.

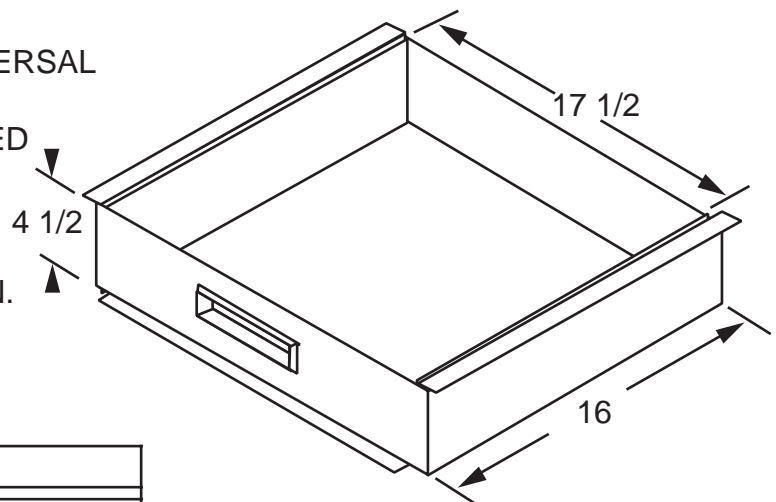

STOCK LIST

ITEM	QTY.	DESCRIPTION
1	1	DRAWER ASSEMBLY
2	4	8-32 X 1/2 SELF-TAPPING SCREW

ORDERING NUMBER: 00601000XX

DRAWER ASSEMBLY

FIG. 006010



STOCK LIST

ITEM	QTY.	DESCRIPTION
1	1	DOCUMENT POCKET
2	6	8-32 X 1/2 SELF-TAPPING SCREW

NOTES:

- 1. XX= FINISH CODE; STANDARD FINISH, XX=73 (BEIGE).
- 2. DOCUMENT POCKET IS ATTACHED USING SHEET METAL SCREWS PROVIDED.
- 3. POCKET IS 9-1/2" W X 9" H X 1" D.

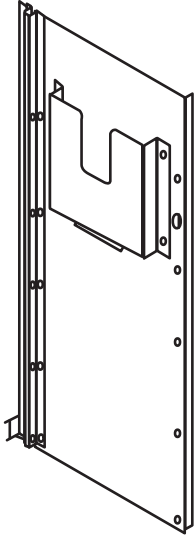

ORDERING NUMBER: 00601100XX

DOCUMENT POCKET

FIG. 006011

STOCK LIST

ITEM	QTY.	DESCRIPTION
1	4	3/8-16 X 6" THREADED STUD
2	4	3/8-16 HEAVY HEX NUT
3	4	3/8 FLAT WASHER
4	4	1/2 PLAIN WASHER
5	4	3/8 LOCK WASHER
6	4	3/8-16 EXPANSION SHIELD

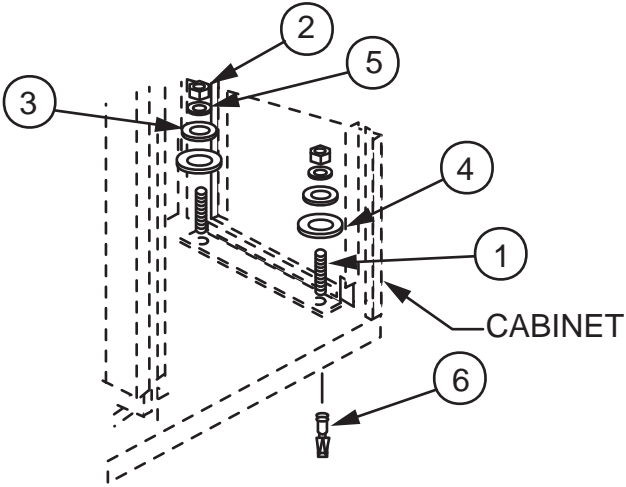

NOTES:

- 1. STANDARD FINISH IS ZINC PLATED AND GOLD CHROMATE.
- 2. LEVELERS REMAIN FUNCTIONAL WHEN ANCHOR KIT IS USED.

ORDERING NUMBER: 0060120010

FLOOR ANCHOR KIT

FIG. 006012



STOCK LIST

ITEM	QTY.	DESCRIPTION
1	2	WALL ANCHOR BRACKET
2	4	1/4-20 X 3/4 CARRIAGE BOLT
3	4	1/4-20 FLAT WASHER
4	4	1/4-20 LOCK WASHER
5	4	1/4-20 HEAVY HEX NUT
6	1	WALL MOUNT BRACKET

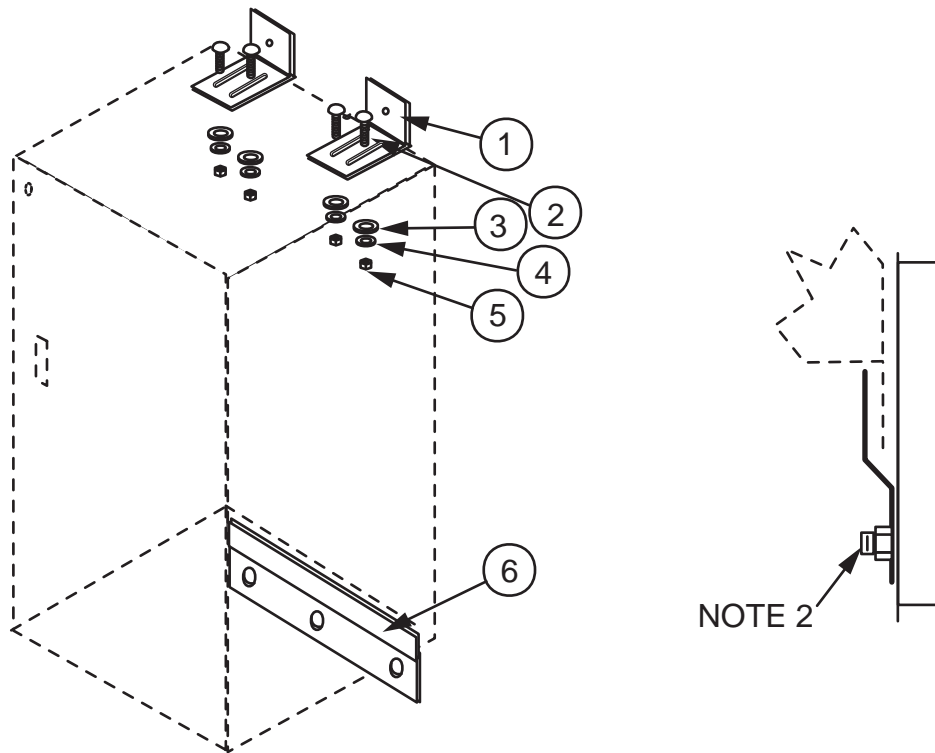

NOTES:

1. XX= FINISH CODE; STANDARD FINISH, XX= 73 (BEIGE). OTHER COLORS AVAILABLE UPON REQUEST.
2. WALL ATTACHMENT HARDWARE IS ORDERED SEPARATELY (REFER TO SECTION 3000).
3. FOR INSULATION KIT REFER TO FIG. 006017.

ORDERING NUMBER: 00601300XX

WALL MOUNTING KIT FOR RACK MOUNTED CABINET

FIG. 006013



NOTES:

1. XX= FINISH CODE; STANDARD FINISH, XX= 73 (BEIGE). OTHER COLORS AVAILABLE ON REQUEST.
2. WALL ATTACHMENT HARDWARE IS ORDERED SEPARATELY (REFER TO SECTION 3000).
3. FOR INSULATION KIT REFER TO FIG. 006018.

STOCK LIST

ITEM	QTY.	DESCRIPTION
1	2	WALL ANCHOR BRACKET
2	4	1/4-20 X 3/4 CARRIAGE BOLT
3	4	1/4-20 FLAT WASHER
4	4	1/4-20 LOCK WASHER
5	4	1/4-20 HEAVY HEX NUT

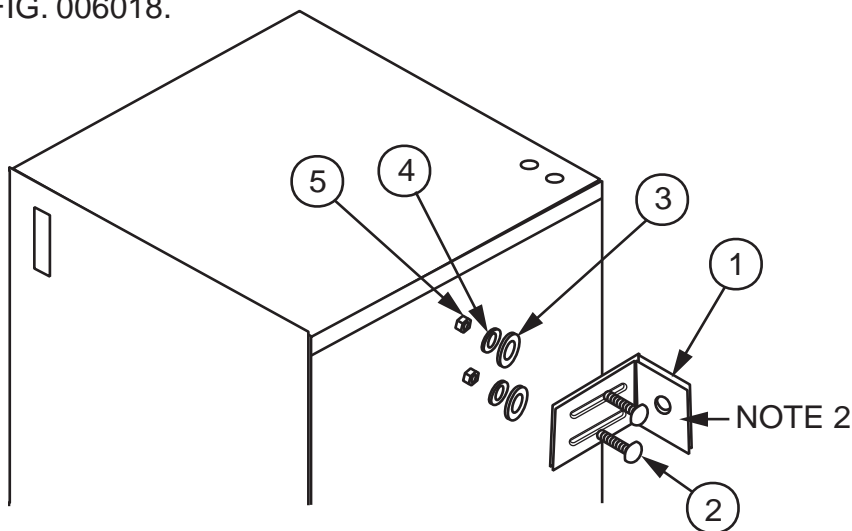

ORDERING NUMBER: 00601400XX

STABILIZING BRACKET FOR 36" OR 72" HEIGHT CABINET

FIG. 006014

NOTES:

1. INSULATOR MATERIAL IS RATED U.L. 94 V-1 AND HAS AN OXYGEN INDEX OF GREATER THAN 29.

STOCK LIST

ITEM	QTY.	DESCRIPTION
1	1	INSULATOR PAD
2	4	BUSHING

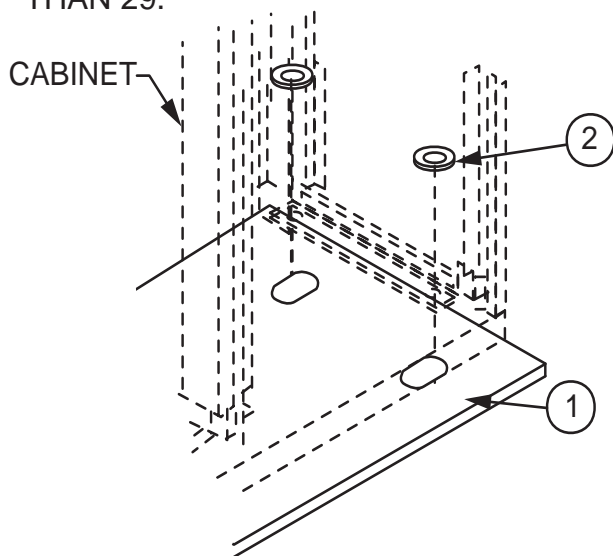

ORDERING NUMBER: 0060150000

FLOOR INSULATION KIT

FIG. 006015



STOCK LIST

ITEM	QTY.	DESCRIPTION
1	2	INSULATOR WASHER
2	2	INSULATOR BUSHING

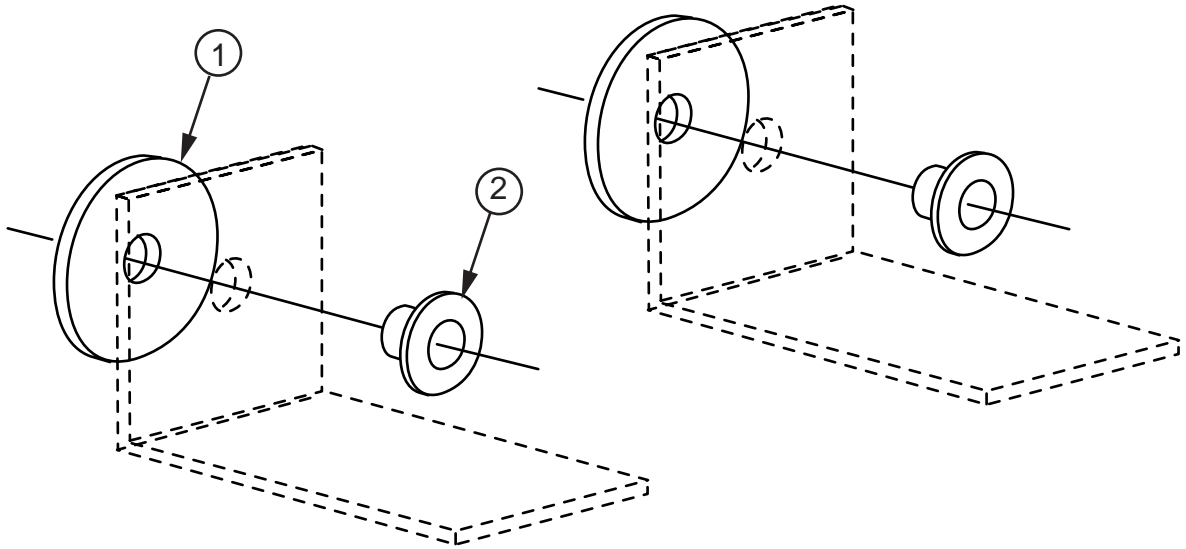

NOTES:

1. INSULATOR MATERIAL IS RATED UL 94 V-1 AND HAS AN OXYGEN INDEX RATING OF GREATER THAN 29.

STABILIZING BRACKET INSULATION KIT
FOR HALF AND FULL HEIGHT CABINET

ORDERING NUMBER: 0060180000
FIG. 006018

 LEVELER KIT
 (SECURED
 INSIDE CABINET)

CABLEWAY COVER
 PLATE KIT

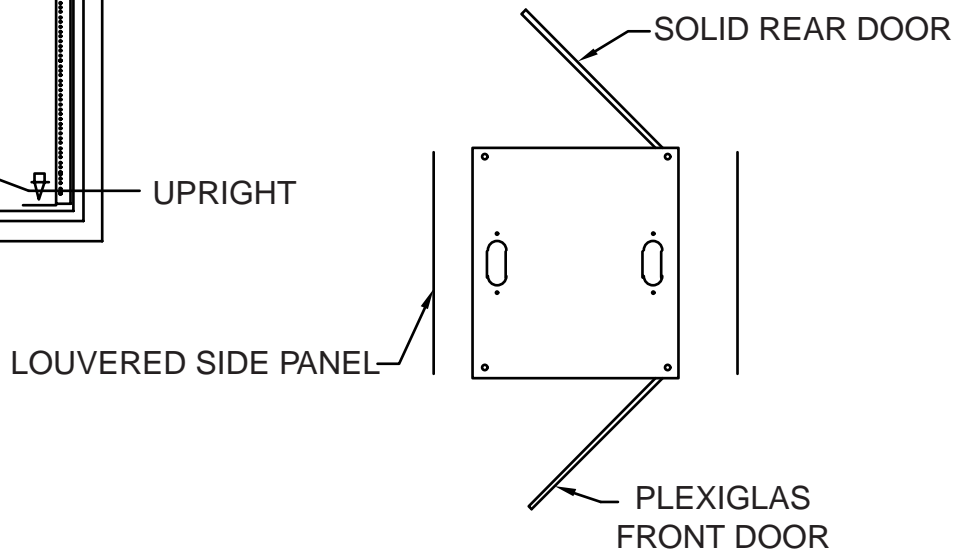
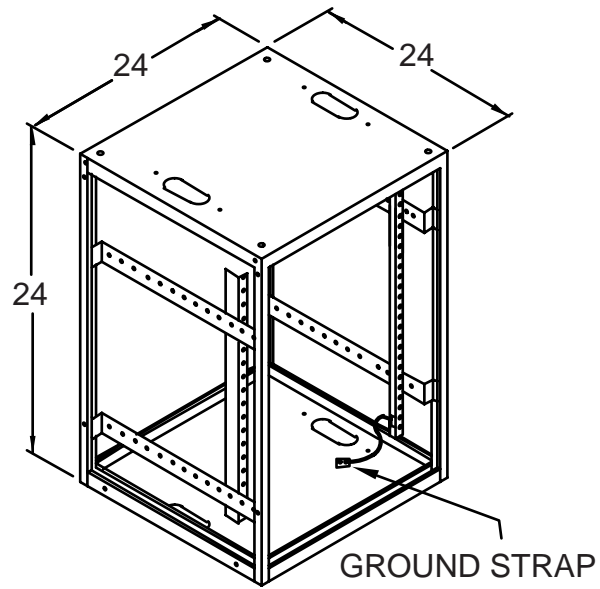
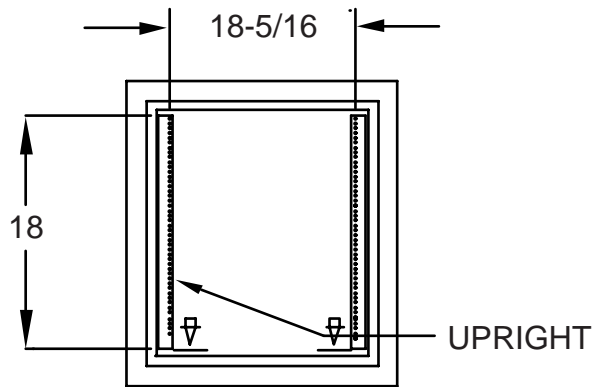
NOTES:

1. XX = FINISH CODE; STANDARD FINISH, XX= 30.
2. INCLUDES FRONT DOOR WITH PLEXIGLAS INSERT, SOLID REAR DOOR, AND TWO LOUVERED SIDE PANELS.
3. REVERSIBLE UPRIGHTS FOR 19" OR 23" EQUIPMENT MOUNTING.

ORDERING NUMBER: 21501100XX

DESK-TOP CABINET, 24"W X 24"H X 24"D

FIG. 215011



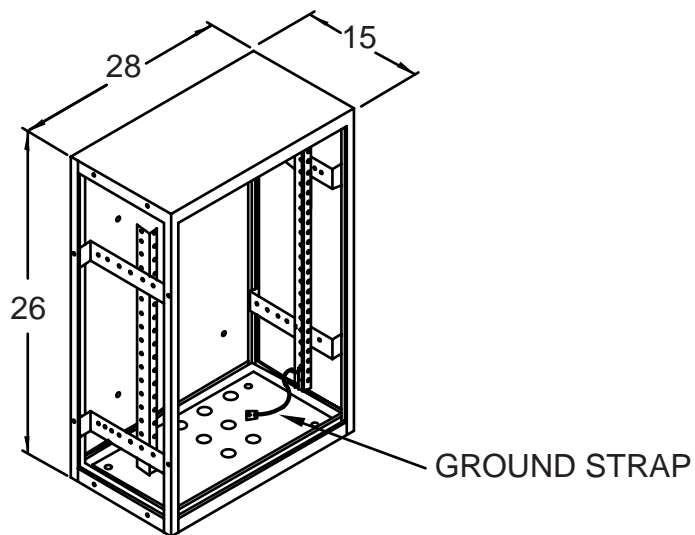
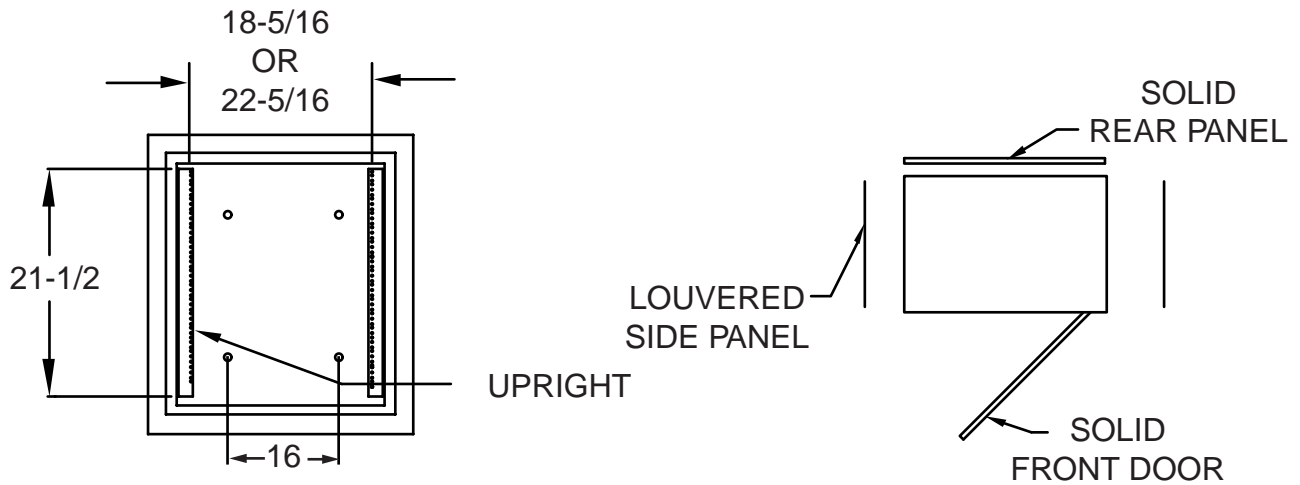

 LEVELER KIT
 (SECURED INSIDE CABINET)

NOTES:

1. XX = FINISH CODE; STANDARD FINISH, XX= 30.
2. INCLUDES SOLID FRONT DOOR, SOLID REAR PANEL, AND TWO LOUVERED SIDE PANELS.
3. REVERSIBLE UPRIGHTS FOR 19" OR 23" EQUIPMENT MOUNTING.
4. FLOOR OR WALL MOUNTABLE. MOUNTING HARDWARE NOT INCLUDED.

ORDERING NUMBER: 21503900XX

CABINET, 26" H X 28" W X 15" D

FIG. 215039



ORDERING TABLE

ORDERING NO.	DIM A	DIM B	DIM C
21185501XX	24	16-35/64	18-5/16
21185502XX	24	20-35/64	22-5/16
21185503XX	16	16-35/64	18-5/16
21185504XX	22-1/2	16-35/64	18-5/16
21185505XX	24	25-19/64	27-1/16
21185506XX	21	16-35/64	18-5/16

STOCK LIST

ITEM	QTY	DESCRIPTION
1	1	SHELF
2	4	BRACKET
3	16	12-24 X 3/8 SHHMS

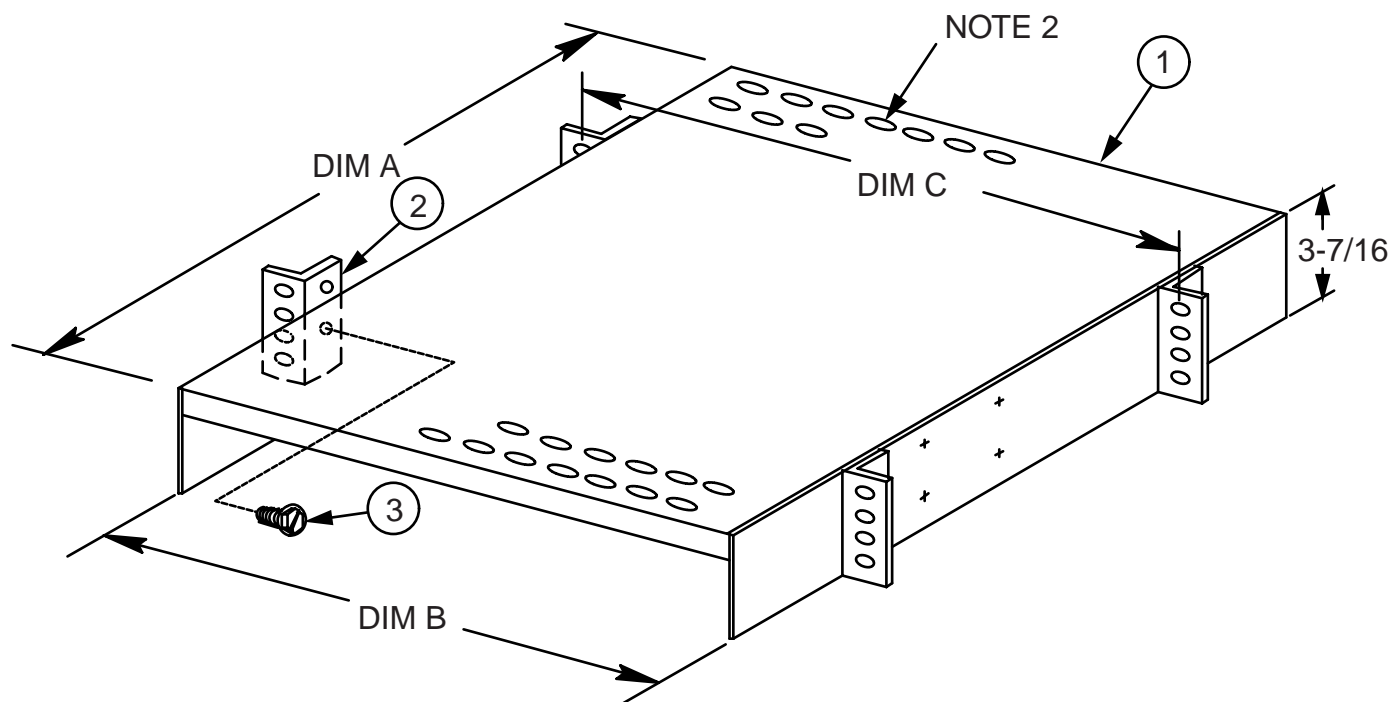

NOTES:

1. XX = FINISH CODE; STANDARD FINISH, XX= 30.
2. VENT HOLES SHOWN ARE REPRESENTATIVE OF ENTIRE SHELF HOLE PATTERN.

ORDERING NUMBER: REFER TO TABLE

SHELF, VENTED, 4-POINT MOUNTING

FIG. 211855