



Async Fiber Optic Dual Modem Card



FEATURES

- Two independent modems per card
- Compatible with FOM-5A and FOM-6A
- Asynchronous transmission
- Data rates up to 19.2 kbps
- Full or half duplex
- Transmission range up to 3 km (2 miles)
- DCE/DTE switch for each modem
- LED indicators for monitoring status

DESCRIPTION

- CMN-CF6A Asynchronous Fiber Optic Dual Modem Card, consists of two fiber optic modems mounted on a single plug-in card for the CMN-16 rack. Each modem is compatible with FOM-5A and FOM-6A short range modems. CMN-CF6A is used for local data distribution, connecting full or half duplex terminals to computers operating over a variety of fiber optic cables. Each modem ensures integrity of data transmission for distances up to 3 km (2 miles).
- The carrier of each modem can be strapped to be constantly on or controlled by the Request to Send signal (Circuit 105). Operation with controlled carrier enables passing of a control signal end-to-end (RTS on CMN-CF6A is passed to DCD on the remote FOM-6A and vice versa).
- Each modem features a switch-selectable DCE/DTE option. This allows it to also operate as a DTE, for connection to another DCE, such as a multiplexer port, without the use of a cross cable.
- Data is transmitted and received over fiber optic cabling, ensuring high immunity to EMI/RFI, and providing security and electrical isolation in hazardous environments.
- The cable shield of each DTE line (RJ-45) can be connected to either the signal ground or to the modem's shielding (switch-selectable).

SPECIFICATIONS

- **Data Rates**
Up to 19.2 kbps
- **Transmission Format**
Asynchronous
- **Transmission Line**
Duplex optical cable
- **Transmission Mode**
Full or half duplex
- **Transmission Controls**
DCD (Circuit 109) turns ON after recognizing receive signal;
CTS (Circuit 106) turns ON after terminal raises RTS (Circuit 105)
- **Carrier Control**
The carrier is strap-selectable for either continuous operation, or switched operation controlled by RTS (Circuit 105)
- **Optical Output Levels**
-26 dBm into 100/140 fiber
-32 dBm into 62.5/125 fiber
-36 dBm into 50/125 fiber
- **Receiver Sensitivity**
-45 dBm
- **Operating Wavelength**
850 nm
- **Indicators**
PWR Power
Modems A and B:
XMT Transmit Data
RCV Receive Data
DCD Data Carrier Detect
- **Terminal Interface**
EIA RS-232/ ITU V.24 via two RJ-45 sockets, one for each modem
- **Fiber Optic Interface**
Optical connectors:
SMA, ST or FC (see *Ordering*)

CMN-CF6A

Async Fiber Optic Dual Modem Card

- Power**
 0.45W, derived from the CMN-16 power supply
- Physical**
 Length: 177 mm / 6.9 in
 Width: 67 mm / 2.6 in
 Height: 15 mm / 0.5 in
 Weight: 85g / 2.9 oz
- Environment**
 Temperature: 0-50°C / 32-122°F
 Humidity: up to 90%, non-condensing

from the fiber optic connectors and connect the cable to the unit. Observe the following instructions:

- TX on the local unit connects to RX on the remote unit
- RX on the local unit connects to TX on the remote unit.

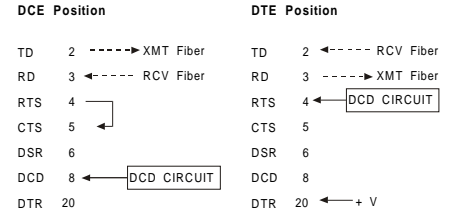

Figure 2. DCE/DTE Switch Configuration

INSTALLATION

- The DCD/DTE switch is factory-set to DCE. Change to DTE, if required (see Figure 1 and Figure 2).
- Set the carrier strap to either ON (carrier continuously ON), or CTRL (carrier controlled by RTS) (factory setting - ON) (see Figure 1).
- Set the delay strap to either 2 msec or 15 msec RTS/CTS delay (factory setting - 2 msec) (see Figure 1).
- Set S1 and S2 to connect the cable shield to the signal ground and chassis (see Table 1).
- Remove the blank panel (if supplied), insert the card into the slot through the rear of CMN-16 rack and secure it with the screws provided.
- Connect the RS-232/V.24 cables to the RJ-45 sockets marked V.24 (see Table 2).
- Remove the plastic dust caps

Table 1. Cable Shield Strapping

S1	S2	Shield connected to:
OFF	OFF	Not connected
OFF	ON	Modem's shielding
ON	OFF	Signal ground
ON	ON	Both

Table 2. DTE/Line Connections (RJ-45)

Pin No.	Name	Description
DTE (V.24) Connections+		
1	CH. GND	Chassis Ground
2	RTS	Request To Send
3	RD	Receive Data
4	DCD	Data Carrier Detect
5	TD	Transmit Data
6	DTR	Data Terminal Ready
7	SIG. GND	Signal Ground
8	CTS	Clear To Send

ORDERING

CMN-CF6A/*
 Async Fiber Optic Dual Modem Card for CMN-16 Rack

- * Specify optical connector type:
SMA for SMA connectors
ST for ST connectors
FC for FC connectors

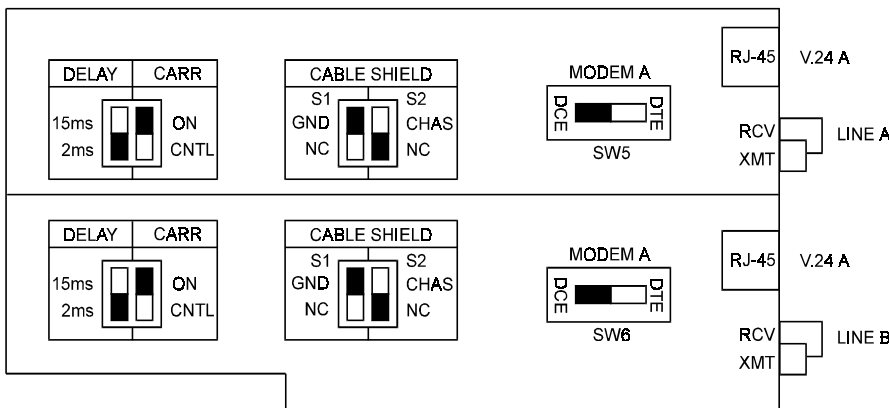

Figure 1. Strapping Diagram



data communications

<http://www.rad.com>

- Corporate Headquarters**
 12 Hanechoshet Street
 Tel Aviv 69710, Israel
 Tel: (972) 3-6458181
 Fax: (972) 3-6498250, 6474436
 Email: rad@rad.co.il
- U.S. Main Office**
 900 Corporate Drive
 Mahwah, NJ 07430
 Tel: (201) 529-1100
 Fax: (201) 529-5777
 Email: market@radusa.com

697-113-05/99